

PPG Heartrate Sensor

Stage 1: Transresistance Amplifier (w/ LP response)

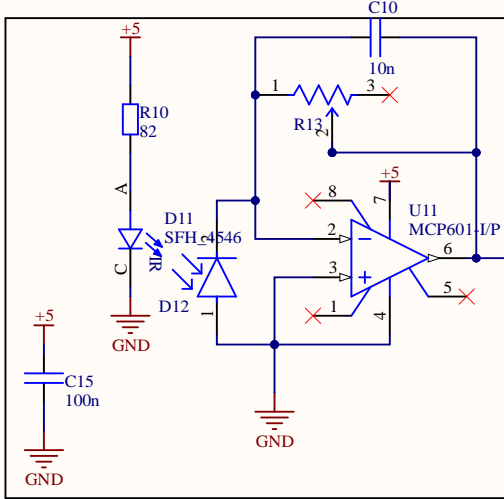

Stage 2: High pass filter and gain

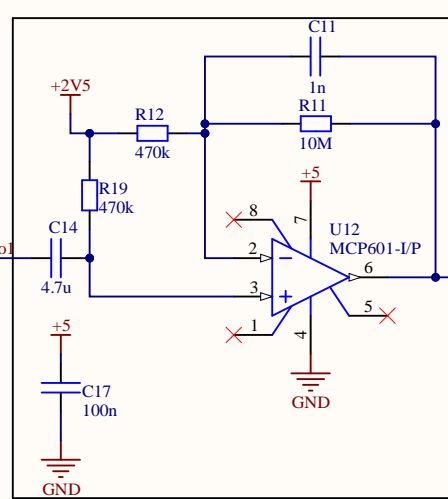

Stage 3: Comparator

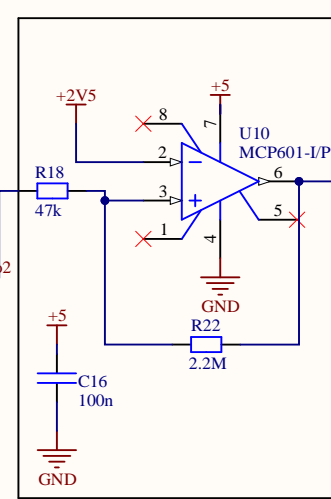

Stage 4: Pulse Generator

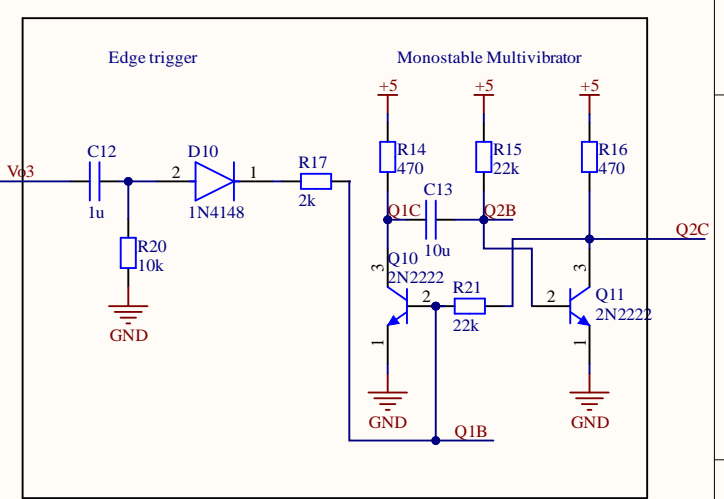

Power: USB and Terminal Block

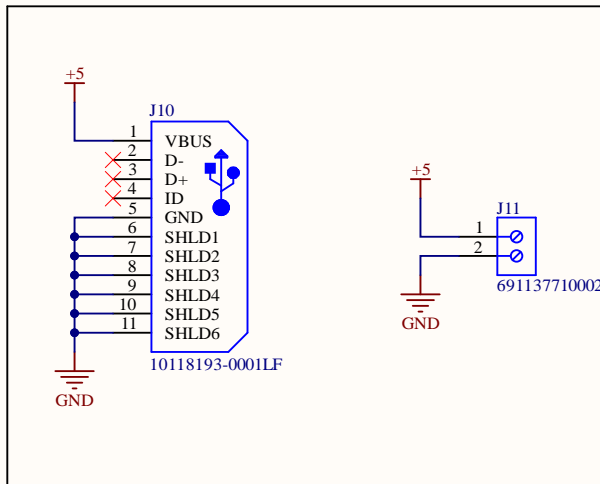

Unity Gain Amplifier - Voltage Reference for 2.5V

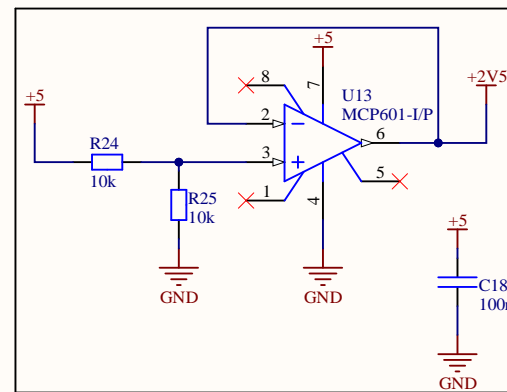

Debug Connector

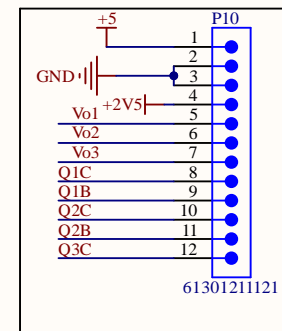

Stage 5: LED Driver

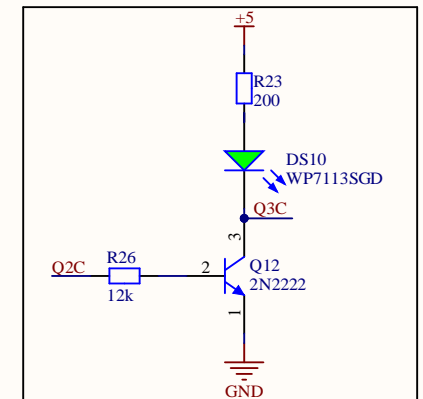

Title		
PPG Heartrate Sensor - Shivam Kataria		
Size	Number	Revision
A4		
Date:	5-21-2026	Sheet of
File:	\\.\main.SchDoc	Drawn By: